

KJWORKS

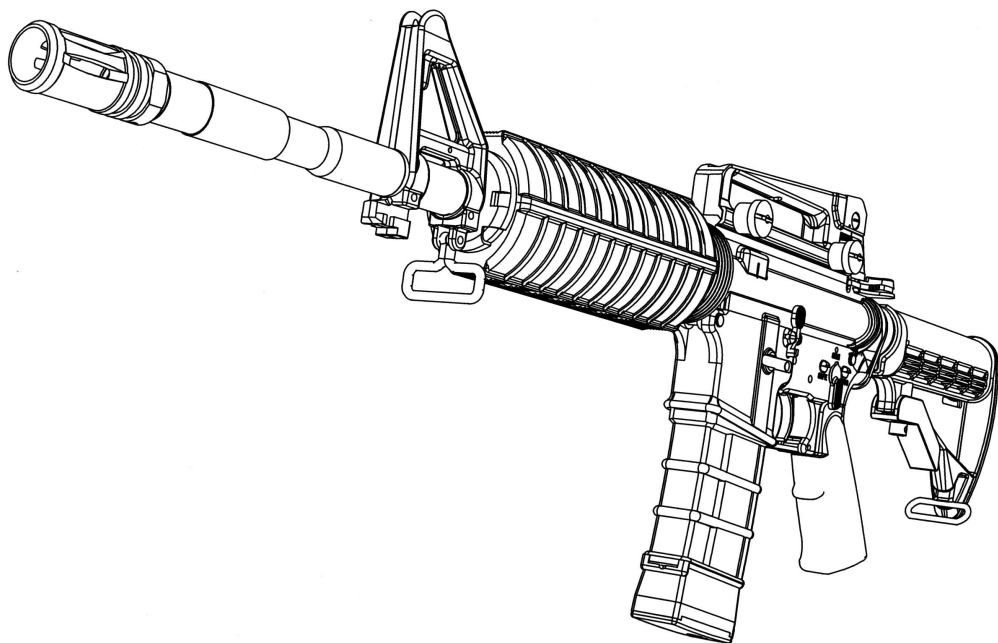

KJ-M4_{v3} MANUAL

WARNING:

BEFORE USAGE, THE INSTRUCTION MUSE BE READ.

THANK YOU FOR PURCHASING. THE FOLLOWING ATTENTION POINTS AND INSTRUCTIONS MUST BE READ. SHOOTING WITHOUT CAUTION OR USED IMPROPERLY, BLINDNESS OR INJURIES COULD BE LEAD.

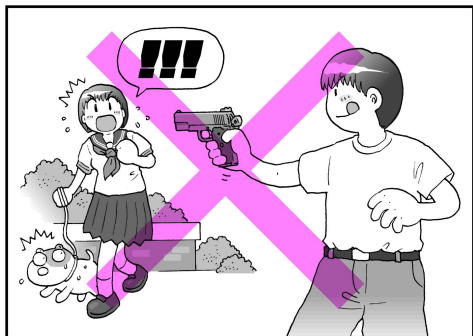

DO NOT POINT AT PEOPLE OR ANIMAL.



GUN AND GAS MUST NOT BE PLACED IN AREA WHERE TEMPERATURE IS OVER 40 °C

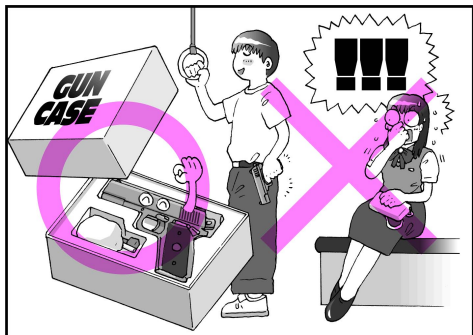

PLACE IN GUN CASE WHEN NOT IN USING OR TRANSPORTING



DO NOT USE GAS WHICH PRESSURE IS OVER 12 Kgs/cm²

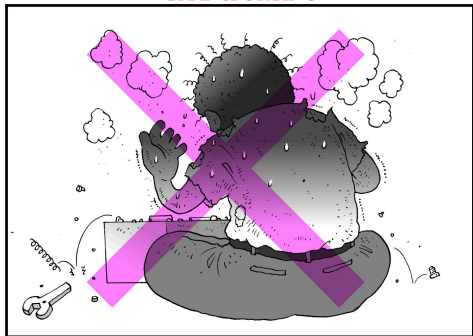

UNAUTHORIZED RECONSTRUCTION OF AIR SOFT GUN TO STRENGTHEN FIRING FUNCTION IS STRICTLY PROHIBITED.



BE CAREFULL WHAT TARGET YOU SHOOT



EYE PROTECTION DEVICE MUST BE EQUIPPED



DO NOT LOAD ANYTHING BUT BB BULLETS.

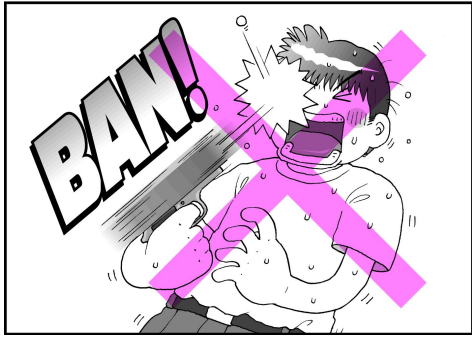

DO NOT LOOK THROUGH THE BARREL

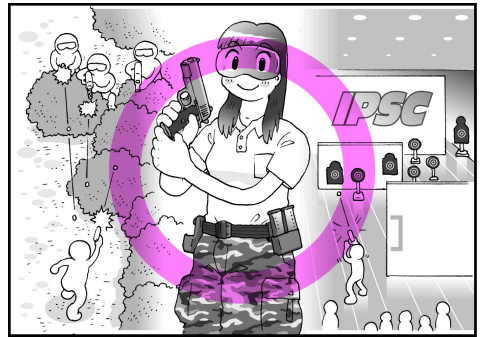

PLEASE SHOOT IN SAFE PLACE

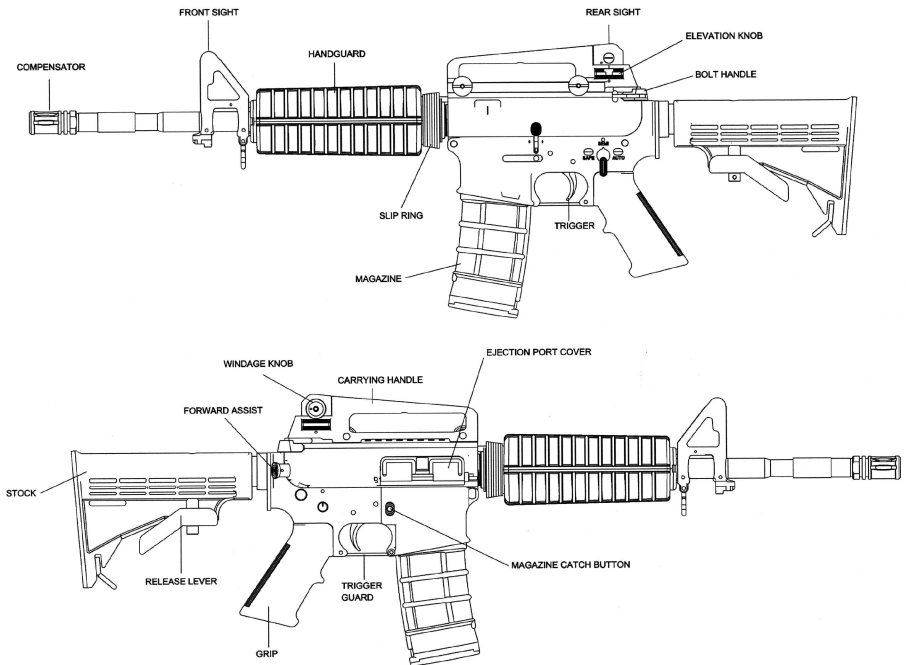

OPERATION

1. PUSH MAGAZINE CATCH BUTTON AND PULL DOWN THE MAGAZINE



4. INSERT MAGAZINE



2. USE BB LOADER TO LOAD BB BULLET.

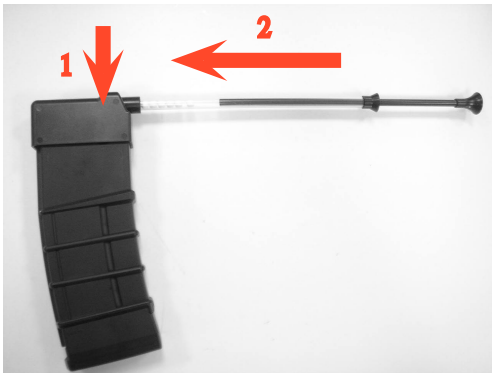

5. PULL CHARGING HANDLE

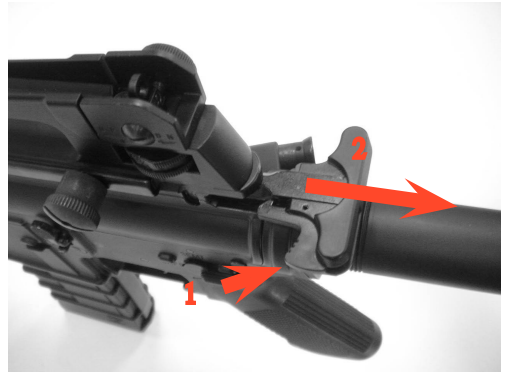

3. FILLING GAS



6. RELEASE CHARGING HANDLE



7. MAKE SURE THERE IS NO GAP BETWEEN BOLT AND CHAMBER



9. SWITCH FIRE CONTROL SELECTOR



8. PUSHING FORWARD ASSIST IF THERE IS A GAP



FOLLOW THE DIRECTION



ATTENTION: ONLY SWITCH WHEN HAMMER IS COCKED

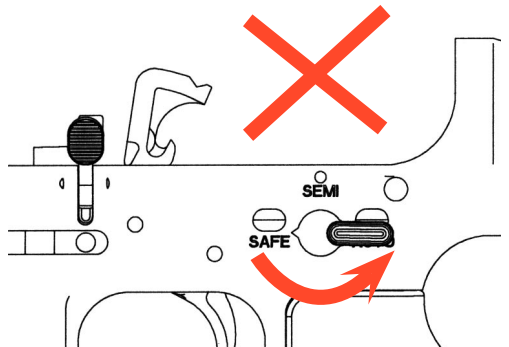
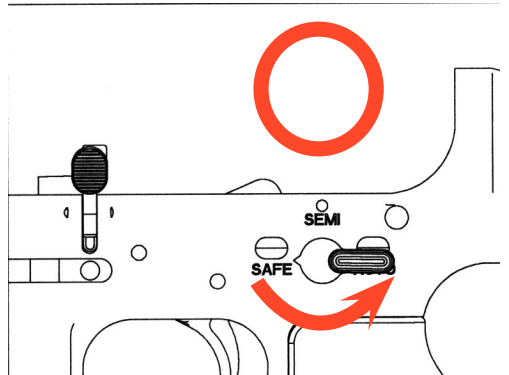

FULL AUTO

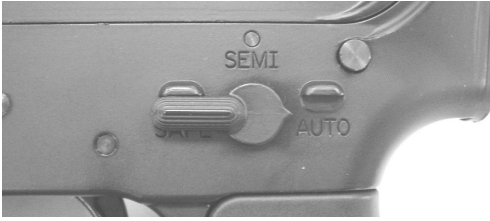

SEMI-AUTO



10. PULL THE TRIGGER



11. BOLT STOP

BOLT WILL BE CAUGHT IN BACK POSITION WHEN RUN OUT OF BULLETS



SWITCH BLANK MODE LEVER TO DECIDE THE BOLT WILL BE CAUGHT OR NOT WHEN RUN OUT OF BULLET



**BLANK
MODE ON**



**BLANK
MODE OFF**

12. RELEASE THE MAGAZINE



13. ADJUST STOCK

PRESS ADJUST LEVER TO ADJUST STOCK

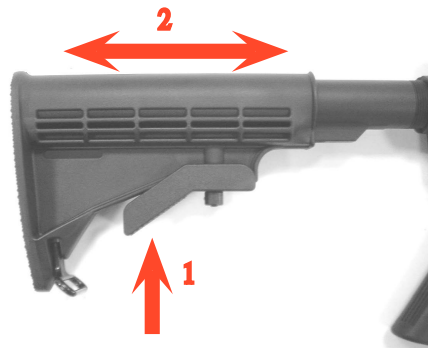

DEPRESS GUARD PLUNGER AND OPEN THE TRIGGER GUARD WHEN WEARING ARCTIC MITTENS

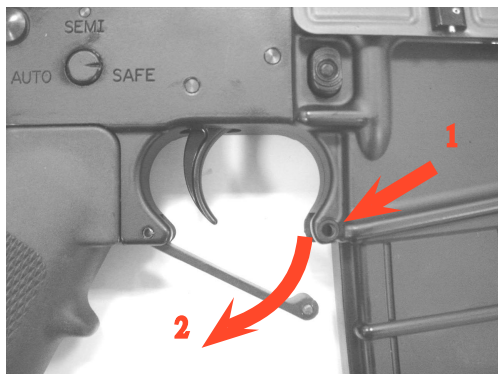

ROTATING ANTICLOCKWISE WHEN IMPACT POINT IS IN RIGHT

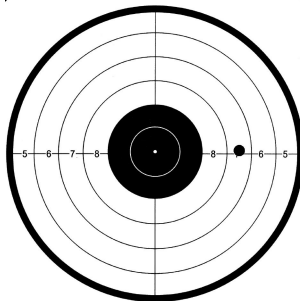

14. ADJUST REAR SIGHT

PLACE FRONT SIGHT IN THE CENTER OF REAR SIGHT

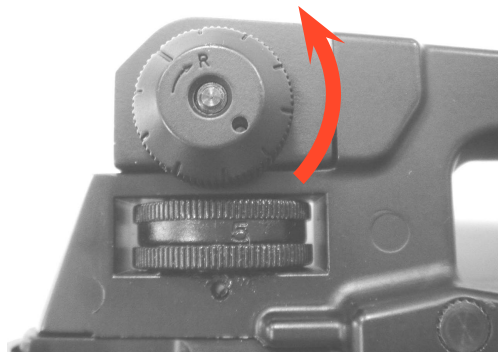

ROTATING CLOCKWISE WHEN IMPACT POINT IS IN LEFT

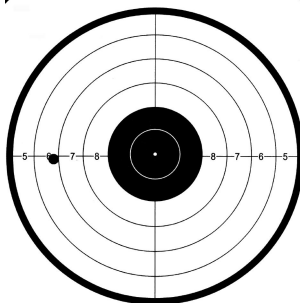

ROTATING WINDAGE KNOB AND ELEVATION KNOB TO ADJUST REAR SIGHT

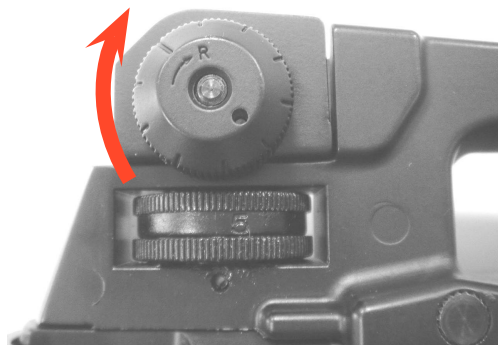
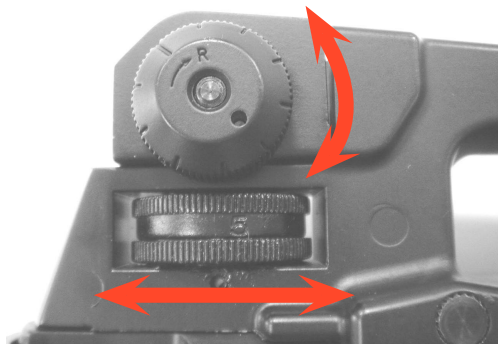

15. TREJECTORY ADJUSTMENT

ROTATING HOP DIAL TO ADJUST TREJECTORY

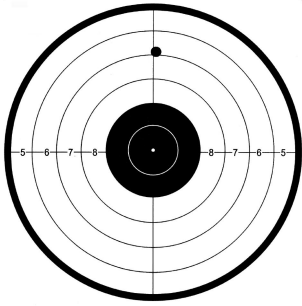

RAISING FRONT SIGHT WHEN IMPACT POINT IS HIGH

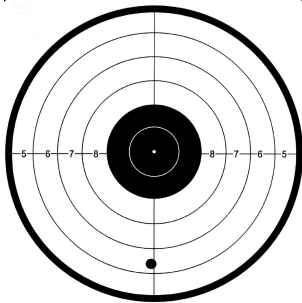
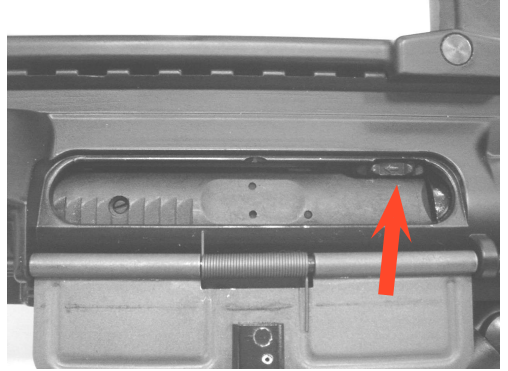
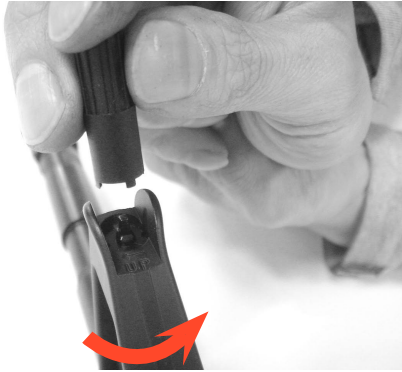

LOWERING FRONT SIGHT WHEN IMPACT POINT IS LOW

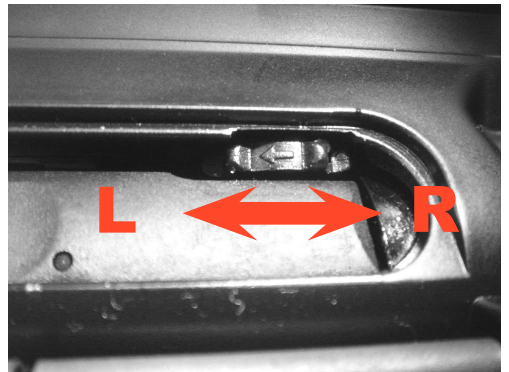
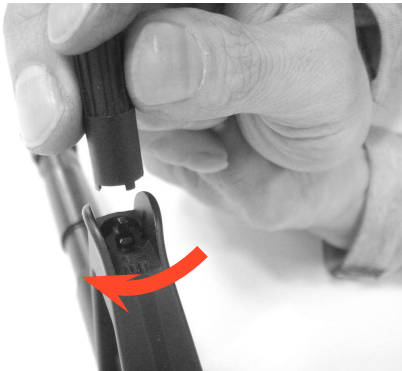

ADJUST ACCORDIND TO TREJECTORY

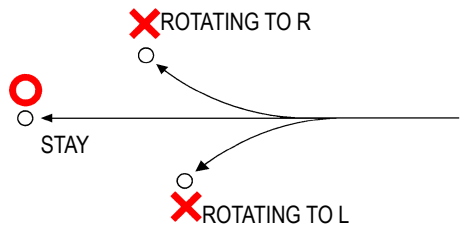

DISASSEMBLE

1. PUSH MAGAZINE CATCH BUTTON AND PULL DOWN THE MAGAZINE



2. PULL CHARGING HANDLE

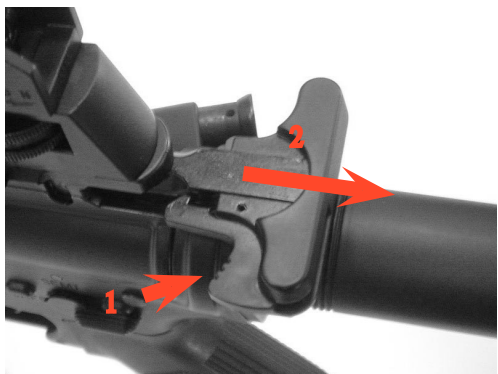

3. CHECK THE CHAMBER TO MAKE SURE THERE IS NO BULLET IS LOAD

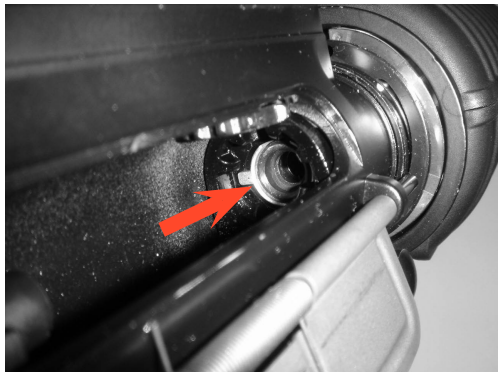

4. SWITCH FIRE SELECTOR TO SAFE POSITION



5. PUSH TAKE DOWN PIN



6. OPEN UPPER RECEIVER



7. PULL CHARGING HANDLE AND BOLT



ASSEMBLY

1. PUT BACK BUFFER AND SPRING



8. PRESS BUFFER RETAINER



2. PUT CHARGING HANDLE AND BOLT BACK

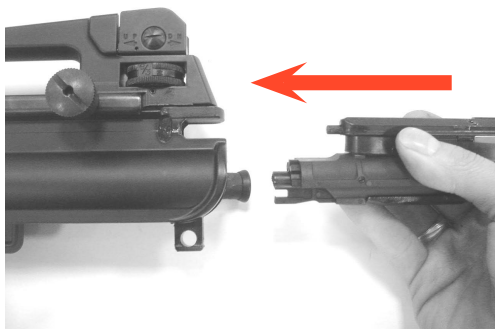

9. REMOVE BUFFER AND SPRING

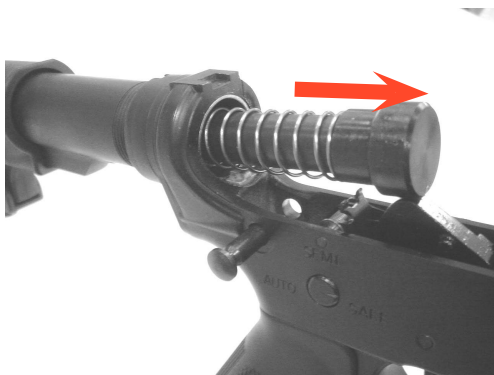

3. CLOSE UPPER RECEIVER AND PUSH BACK TAKEDOWN PIN

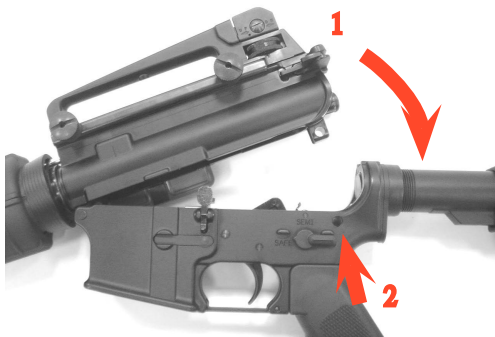

MAGAZINE EXPLODED DRAWING

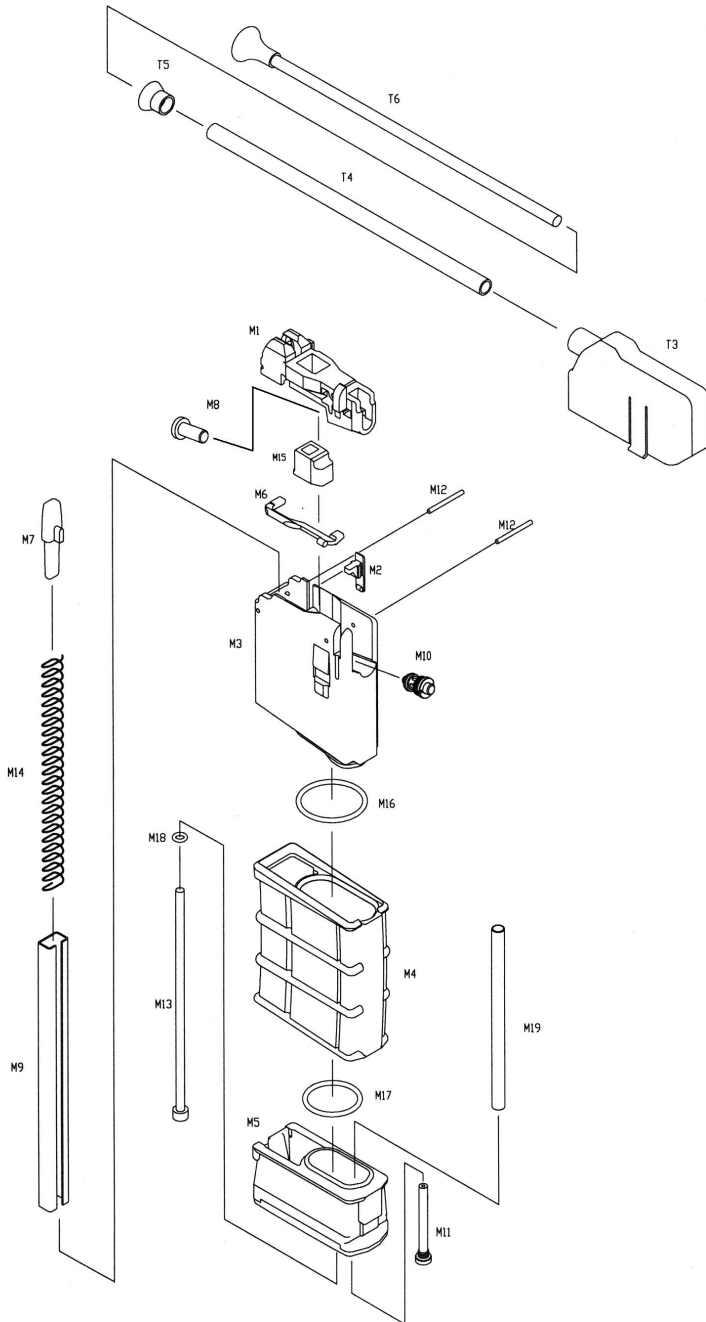

M4 V3 EXPLODED DRAWING

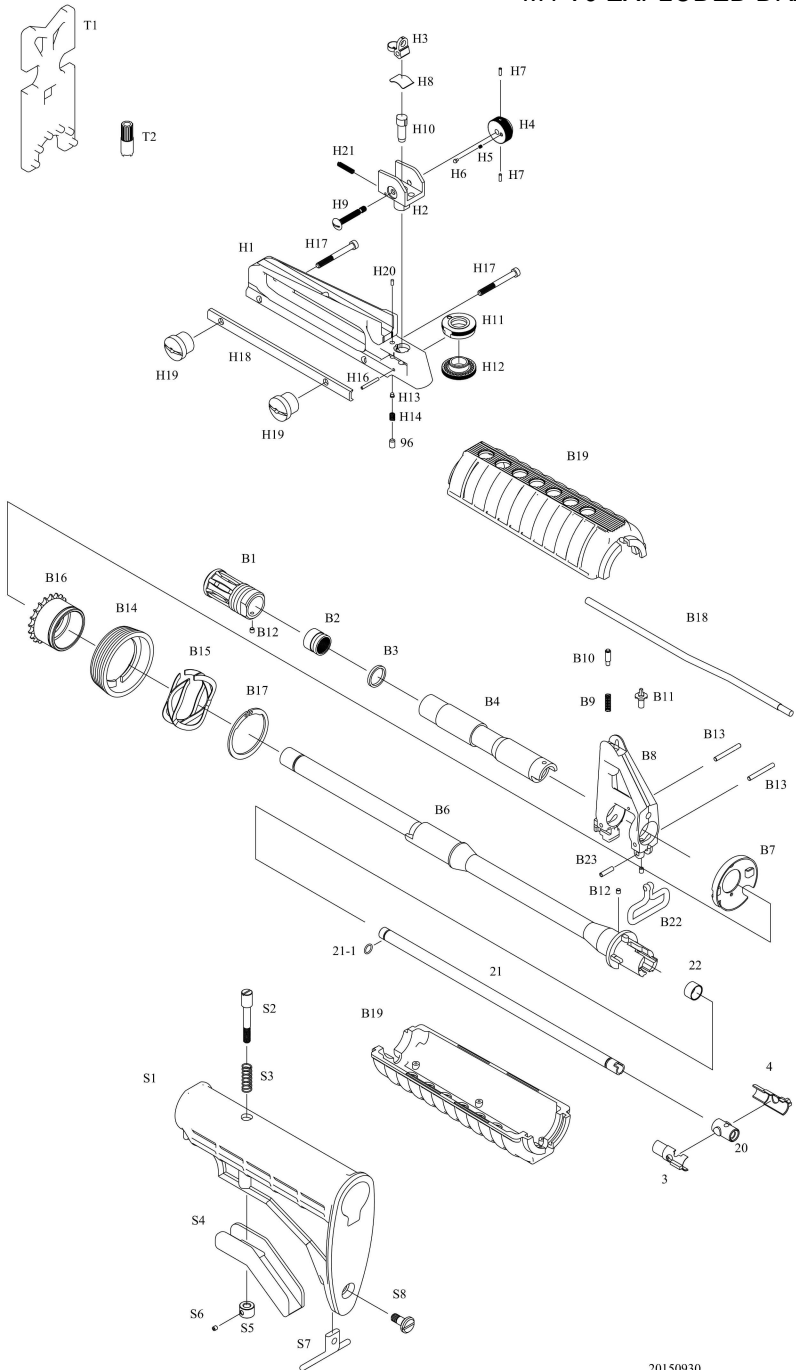

NO.	NAME OF PART	PRICE	NO.	NAME OF PART	PRICE
1	UPPER RECEIVER	2400	47	KNOCKER	160
2N	FEEDING LAMP	250	47A	KNOCKER PART A	40
3	CHAMBER COVER(L)	180	47B	KNOCKER PART B	40
4	CHAMBER COVER(R)	180	48	TRIGGER GUARD	180
5	HOP BASE	120	49	BUFFER RETAINER	180
6N	HOP PLATE	120	50N	RECEIVER EXTENSION	1200
9	PISTON RING	80	50-2	RECEIVER EXTENSION NUT	300
10	CHARGING HANDLE	400	51N	RECEIVER END PLATE	300
11	BOLT GUIDE	160	52N	RECEIVER EXTENSION CAP	240
12	FORWARD ASSIST	180	52AN	RECEIVER EXTENSION CAP O-RING	30
13	FORWARD ASSIST PLATE	60	53	BUFFER	360
14AN	DUSTBIN COVER BROCK A	60	54	BOLT CATCH	300
14BN	DUSTBIN COVER BROCK B	60	55	GRIP	600
14CN	SCREW	20	56	VALVE LOCK PLATE	240
14DN	SPRING	20	57	AUTO SEAR	240
16	HOP DIAL	60	58	RECEIVER PIVOT PIN	200
17	FLOATING VALVE	60	59	TAKE DOWN PIN	200
17A	FLOATING VALVE O-RING	20	60	TRIGGER GUARD PIVOT PIN	30
18	EJECTION PORT COVER	240	62	SEAR PIN	30
19	CHARGING HANDLE LATCH	100	63	SEAR PIN SLEEVE	50
20	RUBBER CHAMBER	180	64	BOLT CATCH PIN	30
21	INNER BARREL	420	65	HAMMER PIN	30
21-1	INNER BARREL O-RING	30	66	TRIGGER GUARD PLUNGER	30
22	CHAMBER RING	100	67	TAKE DOWN PIN DETENT	20
25	DUSTBIN COVER PIN	60	69A	TRIGGER PIN	30
25A	DUSTBIN COVER PIN E-RING	20	69B	TRIGGER PIN TUBE	30
27	FORWARD ASSIST PIN	30	70	HAMMER SPRING	60
28	FORWARD ASSIST PLATE PIN	30	71	TRIGGER SPRING	30
29N	DUSTBIN COVER STOP PIN	30	72	AUTO SEAR SPRING	60
30	CHARGING HANDLE LATCH PIN	30	73	VALVE KNOCKER SPRING	60
31	HOP PLATE SPRING	30	74	RECOIL SPRING	200
34	EJECTION PORT COVER SPRING	30	75	MAGAZINE RELEASE SPRING	60
35	FLOATING VALVE SPRING	30	76	VALVE LOCK PLATE SPRING	30
36	CHARGING HANDLE LATCH SPRING	30	77	TAKE DOWN PIN DETENT SPRING	20
37N	LOWER RECEIVER	2800	78	BUFFER RETAINER SPRING	20
38N	VALVE KNOCKER BASE(L)	180	79	FIRE SLECTOR SPRING	20
39N	VALVE KNOCKER BASE(R)	180	80	TRIGGER GUARD SPRING	20
39-1	VALVE KNOCKER BASE PIN	20	81	DISCONNECTOR SPRING	20
40	HAMMER	200	82	FORWARD ASSIST SPRING	30
41	TRIGGER	220	83	FORWARD ASSIST PLATE SPRING	20
42	DISCONNECTOR	180	84	BOLT CATCH SPRING	20
43	FIRE CONTROL SLECTOR	240	85	HOP DIAL SCREW	80
44	FIRE CONTROL SLECTOR DETENT	30	85A	HOP DIAL SCREW O-RING	20
45	MAGAZINE CATCH	240	86	FEEDING LAMP SCREW	20
46	MAGAZINE CATCH BUTTON	180	87	BUFFER RETAINER SCREW	20

NO.	NAME OF PART	PRICE	NO.	NAME OF PART	PRICE
92	GRIP SCREW	30	H13	ELEVATION KNOB DETENT	40
93	GRIP SCREW WASHER	20	H14	ELEVATION KNOB DETENT SPRING	20
94	HOP DIAL SPECER	60	H16	REAR SIGHT BASE PIN	20
95	TAKE DOWN PIN DETENT SCREW	20	H17	HANDLE SCREW	80
96	TRIGGER GUARD WINDAGE DRUM SCREW	30	H18	HANDLE RAIL	200
97	RECEIVER EXTENSION SCREW	20	H19	HANDLE NUT	100
110N	PISTON1	300	H20	ELEVATION KNOB PIN	20
111	CYLINDER PIN	60	H21	REAR SIGHT BASE SPRING	20
112N	PISTON SPRING	60	S1	STOCK	600
113	PISTON2	80	S2	STOCK LOCKING PIN	100
114	PISTON PIN	20	S3	STOCK LOCKING PIN SPRING	30
116N	BOLT	600	S4	RELEASE LEVER	150
118	BOLT PIN	20	S5	STOCK LOCKING NUT	100
B1	COMPENSATOR	480	S6	STOCK LOCKING NUT SCREW	20
B2	COMPENSATOR SLEEVE	180	S7	STOCK SWIVEL	200
B3	COMPENSATOR WASHER	80	S8	STOCK SWIVEL SCREW	60
B4	OUTTER BARREL SLEEVE	480	M1	MAGAZINE UPPER COVER	120
B6	OUTTER BARREL	960	M2	BLANK MODE LEVER	80
B7	HANDGUARD	240	M3	MAGAZINE UPPER BODY	500
B8	FRONT SIGHT ASSEMBLY BASE	400	M4	MAGAZINE JOINT BODY	400
B9	HELICAL SPRING	20	M5	MAGAZINE UNDER BODY	500
B10	FRONT SIGHT DETENT	50	M6	BB FOLLOWER LINK	120
B11	FRONT SIGHT	80	M7	FOLLOWER	80
B12	FRONT SIGHT ASSEMBLY BASE SCREW	20	M8	VALVE SLEEVE	80
B13	TUBULAR RIVET	30	M9	BB GUIDE	240
B14	HANDGUARD SLIP RING	300	M10	EX VALVE	180
B15	HANDGUARD SLIP RING SPRING	180	M11	CHARGING VALVE	200
B16	BARREL NUT	380	M12	MAGAZINE UPPER COVER PIN	20
B17	RETAINING RING	80	M13	MAGAZINE JOINT SCREW	60
B18	GAS TUBE	120	M14	FOLLOWER SPRING	80
B19	HANDGUARD	200	M15	MAGAZINE GASKET	120
B22	FRONT SWIEVL	200	M16	MAGAZINE JOINT GASKET O-RING 1	30
B23	FRONT SWIVEL PIN	20	M17	MAGAZINE JOINT GASKET O-RING 2	30
H1	HANDLE	1200	M18	JOINT SCREW GASKET	20
H2	REAR SIGHT BASE	280	M19	MAGAZINE TUBE	80
H3	REAR SIGHT	160	T1	BARREL NUT WRENCH	300
H4	WINDAGE KNOB	180	T2	FRONT SIGHT ADJUSTMENT TOOL	80
H5	WINDAGE KNOB DETENT SPRING	20	T3	LOADER	120
H6	WINDAGE KNOB DETENT	40	T4	LOADER TUBE	20
H7	WINDAGE KNOB SCREW	30	T5	LOADER FUNNEL	30
H8	FLAT SPRING	80	T6	LOADER STICK	60
H9	WINDAGE KNOB ADJUST SCREW	100			
H10	REAR SIGHT BASE PART	60			
H11	ELEVATION INDEX	160			
H12	ELEVATION KNOB	200			

KJWORKS